

PRODUCT DESCRIPTION

The WTE Series Cabinet is available in 5 different heights and 2 different depths (18.5" & 25.5"). The basic welded cabinet has a 14 gauge bottom panel with a 5" x 16" cable opening, 16 gauge ventilated side panels, a 16 gauge open top panel with a solid 16 gauge filler panel and 1 pair of fully adjustable 11 gauge mounting rails punched and tapped 10-32 holes on standard E.I.A. universal spacing. The cabinet features a ventilated 16 gauge rear door and a 16 gauge solid front door. Both doors are equipped with cylinder locks and keys (keyed the same).

Additionally, a 16 gauge angled lacing bar is supplied with 1/4" x 7/8" holes on 3" centers.

STANDARD FEATURES

- Standard completely welded assembly, offered in 5 different heights and 2 different depths (18.5" & 25.5")
- 14 gauge bottom panel, with 5" x 16" access opening
- 16 gauge ventilated side panels and open top panel, with 16 gauge top filler panel.
- 1 pair, 11 gauge CRS fully adjustable mounting rails, punched and tapped 10-32 holes on standard E.I.A. universal spacing with equipment mounting screws provided.
- 16 gauge CRS factory assembled ventilated rear door with center channel for additional strength, equipped with 4" chrome pull handle and cylinder lock with 2 keys.
- 16 gauge CRS factory assembled solid front door equipped with chrome cylinder lock and 2 keys. Less front door version available, specify suffix "LFD".
- 16 gauge CRS Adjustable cable lacing angle factory mounted with 1/4" x 7/8" holes on 3" centers.
- Finish:
Iron Phosphate cleaned, standard finish is Textured Black, or one of HOME, Inc. many standard baked enamel colors.

Options:

PFDR - Plexiglass Front Door
WTE-11 - D/T Mounting Rails

See side B for specifications.

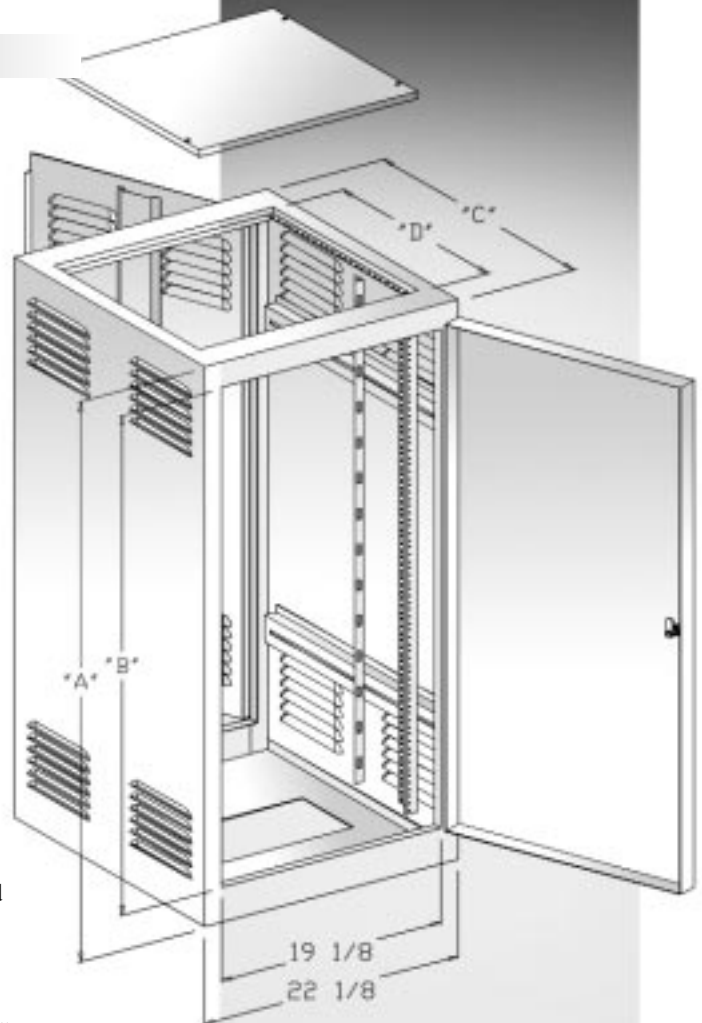

SPECIFICATIONS

CABINET MODEL NO.	RACK UNITS	DIMENSIONS				SHIPPING WEIGHT	LIST PRICE	CABINET MODEL NO.	RACK UNITS	DIMENSIONS				SHIPPING WEIGHT	LIST PRICE
		"A"	"B"	"C"	"D"					"A"	"B"	"C"	"D"		
WTE3675-19-18	21	42"	36 7/8"	18 1/2"	14 1/8"	116 LBS.	718.00	WTE3675-19-25	21	42"	36 7/8"	25 1/2"	21 1/8"	149 LBS.	864.00
WTE4200-19-18	24	47 1/4"	42 1/8"	18 1/2"	14 1/8"	125 LBS.	780.00	WTE4200-19-25	24	47 1/4"	42 1/8"	25 1/2"	21 1/8"	160 LBS.	942.00
WTE6125-19-18	35	66 1/2"	61 3/8"	18 1/2"	14 1/8"	165 LBS.	904.00	WTE6125-19-25	35	66 1/2"	61 3/8"	25 1/2"	21 1/8"	210 LBS.	1016.00
WTE7000-19-18	40	75 1/4"	70 1/8"	18 1/2"	14 1/8"	180 LBS.	964.00	WTE7000-19-25	40	75 1/4"	70 1/8"	25 1/2"	21 1/8"	228 LBS.	1082.00
WTE7700-19-18	44	82 1/4"	77 1/8"	18 1/2"	14 1/8"	202 LBS.	1008.00	WTE7700-19-25	44	82 1/4"	77 1/8"	25 1/2"	21 1/8"	256 LBS.	1132.00
WTE3675-19-18LFD	21	42"	36 7/8"	18 1/2"	14 1/8"	97 LBS.	588.00	WTE3675-19-25LFD	21	42"	36 7/8"	25 1/2"	21 1/8"	131 LBS.	710.00
WTE4200-19-18LFD	24	47 1/4"	42 1/8"	18 1/2"	14 1/8"	100 LBS.	632.00	WTE4200-19-25LFD	24	47 1/4"	42 1/8"	25 1/2"	21 1/8"	135 LBS.	800.00
WTE6125-19-18LFD	35	66 1/2"	61 3/8"	18 1/2"	14 1/8"	129 LBS.	748.00	WTE6125-19-25LFD	35	66 1/2"	61 3/8"	25 1/2"	21 1/8"	174 LBS.	872.00
WTE7000-19-18LFD	40	75 1/4"	70 1/8"	18 1/2"	14 1/8"	135 LBS.	788.00	WTE7000-19-25LFD	40	75 1/4"	70 1/8"	25 1/2"	21 1/8"	185 LBS.	942.00
WTE7700-19-18LFD	44	82 1/4"	77 1/8"	18 1/2"	14 1/8"	152 LBS.	818.00	WTE7700-19-25LFD	44	82 1/4"	77 1/8"	25 1/2"	21 1/8"	206 LBS.	1026.00

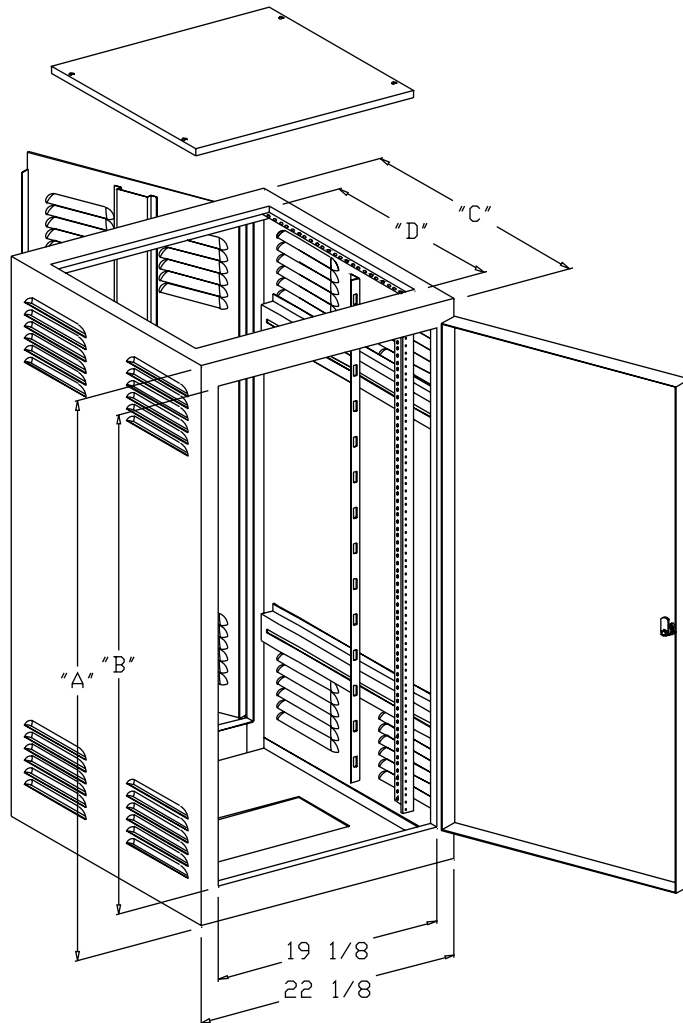

* Contact factory for dealer pricing.

H.O.M.E. Inc. / 500 W. 9th ST. / Hermann, MO 65041
 TEL.: (573) 486-3111 FAX: (573) 486-5737 www.home-inc.net